

Another Battle Won

My dear friend, you have done me a great favor by your explanations and remarks concerning your method. My little doubts, objections, and worries have now been removed, and I think I have broken through to grasp the spirit of the method. Once again I must repeat, the more I become acquainted with the entire course of your analysis, the more I admire you. What great things we will have from you in the future, if only you take care of your health!

—Letter from Wilhelm Olbers to Gauss,
Oct. 10, 1802

WE now have the essential elements, out of which Gauss elaborated his method for determining the orbit of Ceres. Up to this point, the pathway of discovery has been relatively narrow; from now on it widens, and many alternative approaches are possible. Gauss explored many of them himself, in the course of perfecting his method and cutting down on the mass of computations required to actually calculate the elements of the orbit. The final result was Gauss's book, *Theory of the Motion of the Heavenly Bodies Moving about the Sun in Conic Sections*, which he completed in 1808, seven years after his successful forecast for Ceres. As Gauss himself remarked, the exterior form of the method had evolved so much, that it barely resembled the original. Nevertheless, the essential core remained the same.

We have tried to follow Gauss's original pathway as much as possible. That pathway is sketched in an early manuscript entitled, *Summary Overview of the Method Used To Determine the Orbits of the Two New Planets* (the title refers to the asteroids Ceres and Pallas). The *Summary Overview* was published in 1809, but is probably close to, or even identical with, a summary that Gauss prepared for Olbers in the Fall of 1802. The latter document was the subject of several exchanges of letters back and forth between the two astronomers, where Olbers raised various questions and criticisms, and challenged Gauss to explain certain features of the method. Fortunately, that correspondence, which provides valuable insights into Gauss's thinking on the subject, has been published. We shall quote from it in the last chapter, the *stretto*.

Our goal now is to complete Gauss's method for constructing a first approximation to the orbit of Ceres from three observations.

In earlier discussions, we discovered a method for reconstructing the second of the three positions of the planet, P_2 , from the values of two crucial "coefficients"—namely, the ratios of triangular areas $T_{12}:T_{13}$ and $T_{23}:T_{13}$ —together with the data of the three observations and the known motion of the Earth. The difficulty with

our method lay in the circumstance, that the values of required coefficients cannot be adduced from the data in any direct way.

Our initial response was to use, instead of the triangular areas, the corresponding orbital sectors whose ratios $S_{12}:S_{13}$ and $S_{23}:S_{13}$ are known from Kepler's "area law" to be equal to the ratios of the elapsed times, $t_2-t_1:t_3-t_1$ and $t_3-t_2:t_3-t_1$. Unfortunately, the magnitude of error introduced by using such a crude approximation for the coefficients, renders the construction nearly useless. Accordingly, we spent that last three chapters working to develop a method for correcting those values, to at least an additional degree or order of magnitude of precision.

The immediate fruit of that endeavor, was an estimate for the value of the ratio $S_{13}:T_{13}$. As it turned out, S_{13} is larger than T_{13} by a factor approximately equal to

$$1 + \left(2 \times \frac{\pi^2 \times (t_2-t_1) \times (t_3-t_2)}{r_2^3} \right).$$

Let us call that magnitude, slightly larger than one, "G" (for Gauss's correction). So, $S_{13} \simeq G \times T_{13}$. What follows concerning the ratios $T_{12}:T_{13}$ and $T_{23}:T_{13}$?

We already determined, that the main source of error in replacing $T_{12}:T_{13}$ (for example) by the corresponding ratio of orbital sectors, $S_{12}:S_{13}$, comes from the discrepancy between the *denominators*. The percentage error arising from the discrepancy between the *numerators* is an order of magnitude smaller. We can now correct the discrepancy in the denominators, at least to a large extent. S_{13} being larger than T_{13} by a factor of about G , means that the *quotient* of any magnitude by T_{13} , will be larger, by that same factor, than the corresponding quotient of the same magnitude by S_{13} . In particular,

$$\frac{T_{12}}{T_{13}} \simeq G \times \frac{T_{12}}{S_{13}}.$$

If, at this point, we were to replace T_{12} by S_{12} in the numerator, we would thereby introduce an error, an order of magnitude smaller than that which we have just "corrected" using G . Granting that smaller margin of error, and carrying out the mentioned substitution, we arrive at the estimate

$$\frac{T_{12}}{T_{13}} \simeq G \times \frac{S_{12}}{S_{13}} = G \times \frac{t_2-t_1}{t_3-t_1}.$$

For similar reasons,

$$\frac{T_{23}}{T_{13}} \simeq G \times \frac{t_3-t_2}{t_3-t_1}.$$

Recall, that the ratios of the elapsed times constituted our original choice of coefficients for the construction of Ceres' position P_2 . Our new values are nothing but the same ratios of elapsed times, multiplied by Gauss's "correction factor" G . If our reasoning is valid, this simple correction should be enough to yield at least an order-of-magnitude improvement over the original values. By applying the new, corrected coefficients in our geometrical method for reconstructing the Ceres position P_2 from the three observations, we should obtain an order-of-magnitude better approximation to the actual position. *Gauss verified that this is indeed the case.*

The story is not yet over, of course. We still have the successive tasks:

- (i) To determine the other two positions of Ceres, P_1 and P_3 ;
- (ii) To calculate at least an approximate orbit for Ceres; and
- (iii) To successively correct the effect of various errors and discrepancies, until we obtain an orbit fully consistent with the observations and other boundary conditions, taking possible errors of observation into account.

We Face a Paradox

But before proceeding, haven't we forgotten something? Gauss's factor G is not a fixed, *a priori* value, but depends on the *unknown* sun-Ceres distance r_2 . We seem to face an unsolvable problem: we need r_2 to compute G , but we need G to compute the Ceres position, from which alone r_2 can be determined. **(Figure 15.1)**

As a matter of fact, *this kind of self-reflexivity is typical for Gauss's hypergeometrical domain*. Far from constituting the awesome barrier it might seem to be at first glance, the self-reflexive character of hypergeometric and related functions, is key to the extraordinary *simplification* which the *analysis situs*-based methods of Gauss, Riemann, and Cantor brought to the entire non-algebraic domain. These functions cannot be constructed "from the bottom up," but have to be handled "from the top down," in terms of the characteristic singularities of a self-reflexive, self-elaborating complex domain. A "secret" of much of Gauss's work, is how that higher domain efficiently determines all phenomena in the lower domains, including in the realm of arithmetic and visual-space geometry.

It was from this superior standpoint, that Gauss devel-

FIGURE 15.1. A self-reflexive paradox. We need r_2 to compute Gauss's "correction factor" G , but we need G to compute P_2 , from which r_2 is derived.

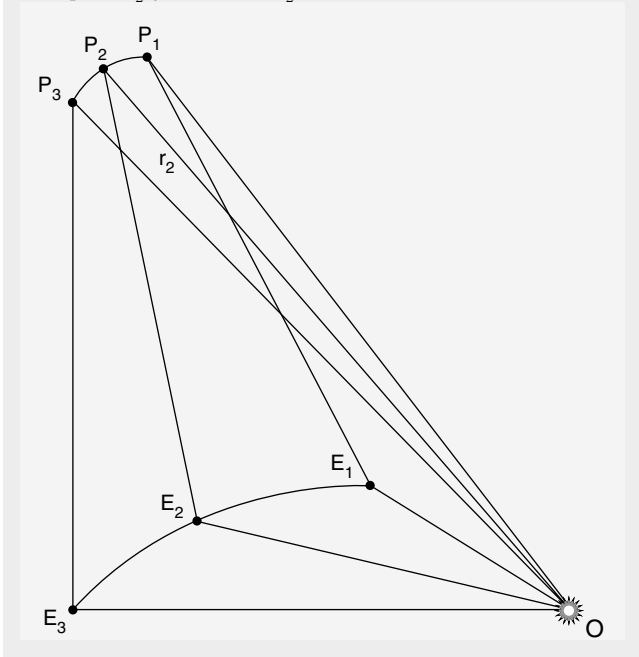

oped a variety of rapidly convergent numerical series for practical calculations in astronomy, geodesy, and other fields. Using those series, we can compute the values of hypergeometric and related functions to a high degree of precision. However, the numerical properties of the series coefficients, their rates of convergence, their interrelationships, and so on, are all dictated "from above," by the *analysis situs* of the complex domain—the same principle which is otherwise exemplified by Gauss's work on bi-quadratic residues. Although an explicit formal development of hypergeometric functions is not necessary for Gauss's original solution, the higher domain is always present "between the lines."

In the present case, Gauss's practical solution amounts to "unfolding the circle" of the reflexive relationship between r_2 and G , into a self-similar process of successive approximations to the required orbit, analogous to a Fibonacci series.

The first step, is to select a suitable initial term, as a first approximation. For the case of Ceres we might conjecture, as von Zach, Olbers, and others did at the time, that the orbit lies in a region approximately midway between the orbits of Mars and Jupiter. That means taking an r_2 close to 2.8 A.U. The corresponding value of G , computed with the help of this value and elapsed times of about 21 days between the three observations, comes out to about 1.003.

Another option, independent of any specific conjecture concerning the position of the orbit, would be to carry through our construction for P_2 without Gauss's correction, and to compute the Ceres-sun distance r_2 from the rough approximation for the Ceres position.

Having selected an initial value for r_2 , the next step is to check, whether it is consistent with the self-reflexive relationship described above. Starting from the proposed value of r_2 and the elapsed times, calculate the corrective factor G from the formula stated above; then, use that G to determine a set of "corrected" coefficients, and construct from those a new estimate for Ceres' position P_2 .

Now, compare the distance between that position and the sun, with the original value of r_2 . If the two values *coincide* to within a tolerable error, then we can regard the entire set of r_2, P_2, G , together with the associated coefficients, as consistent and coherent, and proceed to determine an orbit from them. If the two values of r_2 differ significantly, then we know the posited value of r_2 cannot be correct, and we must modify it accordingly. A mere trial-and-error approach, although feasible, is extremely laborious. Much better, is to "close in" on the required value, by successive approximations which take into account the *functional dependence* of the initial and calculated values, and in particular the *rate of change* of that dependence. By this sort of analysis, which we shall not go into here, Gauss could obtain the desired coincidence (or very near coincidence) after only a very few steps.

How To Find the Other Two Positions of Ceres

Let us move on to the next essential task. Suppose we have succeeded in obtaining a position P_2 and corresponding distance r_2 which are self-consistent with our geometrical construction process, in the sense indicated above. How can we determine the other two positions of Ceres, P_1 and P_3 ?

As we might expect, the necessary relationships are already subsumed by our original construction. Readers should review the essentials of that construction, with the help of the relevant diagrams. Recall, that P_2 was obtained as the intersection of a certain plane Q with the "line of sight" L_2 —the line running from the Earth's second position E_2 in the direction defined by the second observation. The plane Q was determined as follows. First, we constructed point F , in the plane of the Earth's orbit, according to the requirement, that F has the same relationship to the Earth's positions E_1 and E_3 , in terms of the "parallelogram law" of decomposition of displace-

ments, as P_2 has to P_1 and P_3 . (**Figure 15.2a**) For that purpose, we chose points F_1 and F_3 , located on the lines OE_1 and OE_3 , respectively, such that

$$\frac{OF_1}{OE_1} = \text{the estimated value of } \frac{T_{23}}{T_{13}},$$

and

$$\frac{OF_3}{OE_3} = \text{the estimated value of } \frac{T_{12}}{T_{13}}.$$

We then constructed the point F as the endpoint of the combination of the displacements OF_1 and OF_3 —i.e., the fourth vertex of the parallelogram whose other vertices are O , F_1 , and F_3 .

Next, we drew the parallels through F , to the other two “lines-of-sight” L_1 and L_3 . (**Figure 15.2b**) Q is the plane “spanned” by those parallels through F , and the

FIGURE 15.2. (a) We constructed point F using the “parallelogram law” of displacements. (b) Once constructed, plane Q at F must contain P_2 as the point of intersection with line L_2 .

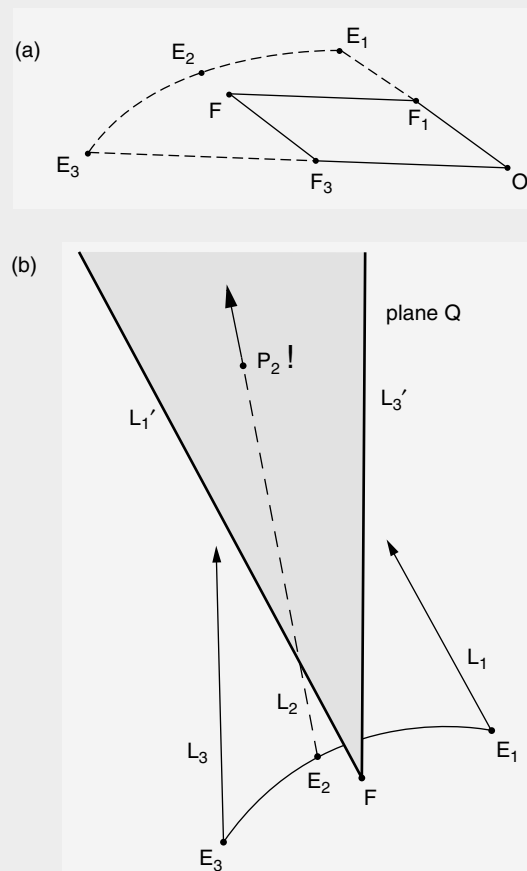

intersection of plane Q with L_2 is our adduced position for P_2 . We showed, that this reconstruction of the position of Ceres would actually coincide with the real one, were it not for a margin of error introduced in estimating the coefficients T_{12}/T_{13} and T_{23}/T_{13} , as well as in Piazzi’s observations themselves. We also found a way to reduce the former error, using Gauss’s correction.

Now, to find P_1 and P_3 , look more closely at the relationships in the plane Q . Call the parallels to the lines L_1 and L_3 , drawn through F , L_1' and L_3' , respectively. (**Figure 15.3**) On each of the latter lines, mark off points P_1' and P_3' , such that the distance FP_1' is equal to the Earth-Ceres distance E_1P_1 , and similarly FP_3' is equal to E_3P_3 . To put it another way: transfer the segments E_1P_1 and E_3P_3 from the base-points E_1 and E_3 , to F , without altering their directions.

What is the relationship of P_2 , to the points F , P_1' , and P_3' ? From the “hereditary” character of the entire construction, we would certainly expect the *same coefficients* to arise here, as we adduced for the relationship of P_2 to O , P_1 , and P_3 , and used in the construction of F . A bit of effort, working through the combinations of dis-

FIGURE 15.3. Having determined the position of P_2 , we now set out to locate P_1 and P_3 , by determining P_1' and P_3' in plane Q at F .

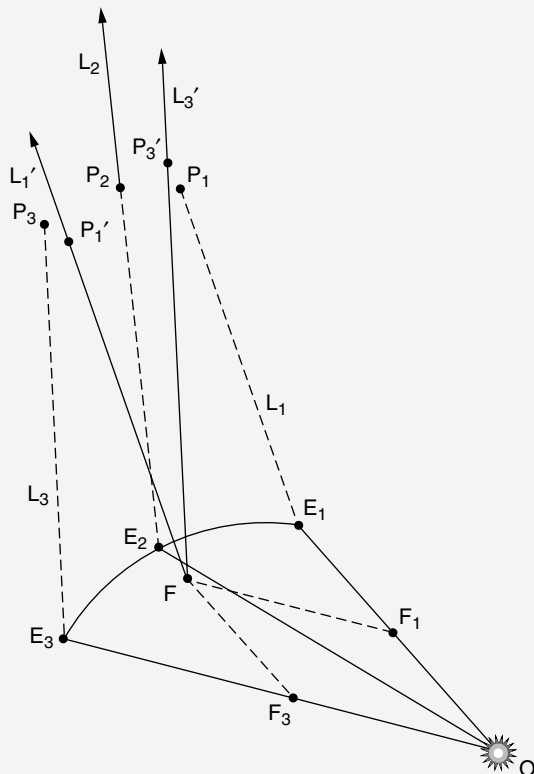

placements involved, confirms that expectation.

This leads us to a very simple construction for P_1 and P_3 . All we must do, is to decompose the displacement FP_2 —a known entity, thanks to our construction—into a combination of displacements along L_1' and L_3' . In other words, construct points Q_1' and Q_3' , along those lines, such that FP_2 is the sum of the displacements FQ_1' and FQ_3' , in the sense of the parallelogram law. (Figure 15.4) (Q_1' and Q_3' are the “projections” of P_2 onto L_1' and L_3' , respectively.) Now, P_1' and P_3' are not yet known at this point, but the “hereditary” character of the construction tells us, as we remarked above, that the values of the ratios

$$\frac{FQ_1'}{FP_1'} \quad \text{and} \quad \frac{FQ_3'}{FP_3'}$$

are the same as the coefficients used in the construction of P_2 , i.e., the estimated values of T_{23}/T_{13} and T_{12}/T_{13} . *Aha!* Using those ratios, we can now determine the distances FP_1' and FP_3' . We have only to divide FQ_1' by the first coefficient, to get FP_1' , and divide FQ_3' by the second coefficient, to get FP_3' . That finishes the job, since the lengths we wanted to determine—namely E_1P_1 and E_3P_3 —are the same as FP_1' and FP_3' respectively, by construction.

Finally, by marking off these Earth-Ceres distances along the “lines of sight” defined by Piazzzi’s observations, we construct the positions P_1 and P_3 , themselves. Another battle has been won!

—JT

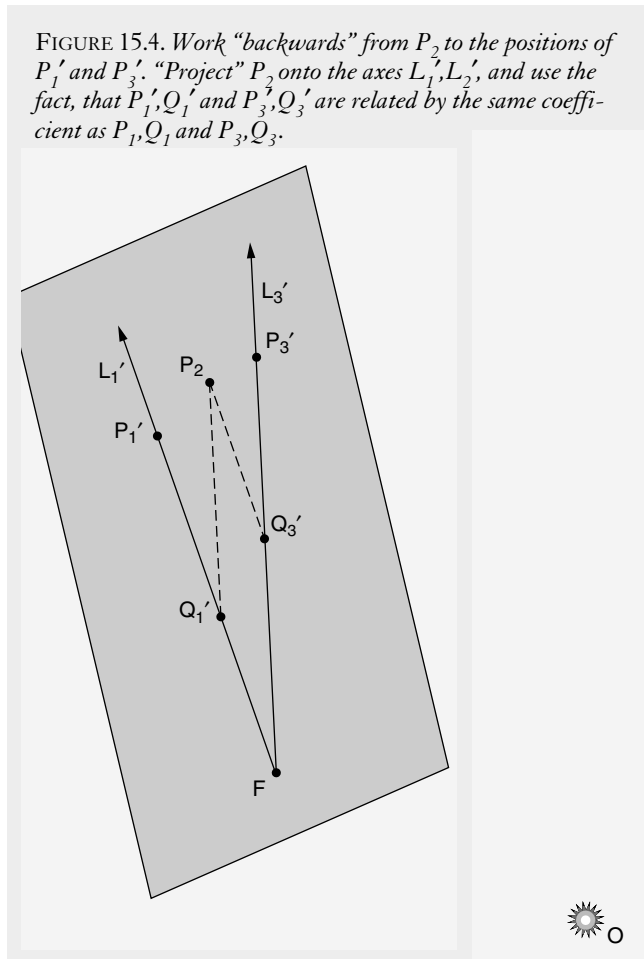

FIGURE 15.4. Work “backwards” from P_2 to the positions of P_1' and P_3' . “Project” P_2 onto the axes L_1', L_3' , and use the fact, that P_1', Q_1' and P_3', Q_3' are related by the same coefficient as P_1, Q_1 and P_3, Q_3 .

CHAPTER 16

Our Journey Comes to an End

In the last chapter, we succeeded in constructing at least to a first approximation, all three of the Ceres positions. Given the three positions P_1, P_2, P_3 what could be easier than to construct a unique conic-section orbit around the sun, passing through those positions? We can immediately determine the location of the plane of Ceres’ orbit, and its inclination relative to the ecliptic plane, by just passing a plane through the sun and any two of the positions.

To determine the shape of the conic-section orbit, apply our conical projection, taking the horizontal plane to represent the plane of Ceres’ orbit. The three points U_1, U_2, U_3 on the cone, which project P_1, P_2, P_3 , determine a unique plane passing through all three in the con-

ical space. The intersection of that plane with the cone is a conic section through U_1, U_2, U_3 ; and the projection of that curve onto the horizontal plane, is the unique conic section through P_1, P_2, P_3 , with focus at the sun. (Figure 16.1)

As simple as this latter method appears, Gauss rejected it. Why? In the case of Ceres, P_1, P_2, P_3 lie close together. Small errors in the determination of those three positions, can lead to very large errors in the inclination of the plane passing through the corresponding points U_1, U_2, U_3 on the cone. The result would be so unreliable as to be useless as the basis for forecasting the planet’s motion.

To resolve this problem, Gauss chooses a different tac-

tic. He leaves P_2 aside for the moment, and proceeds to determine the orbit from P_1 and P_3 and the elapsed time between them. Gauss developed a variety of methods for accomplishing this. The simplest pathway goes via Gauss's orbital parameter, using the "area law." Remember, the value of the half-parameter corresponds to the "height" of the point V on the axis of the cone, where the axis is intersected by the plane defining the orbit. If we know the half-parameter, then that gives us a third point V , in addition to U_1 and U_3 , with which to determine the position of the intersecting plane. Unlike P_2 , the point O lies far from P_1 , and P_3 ; the corresponding points V , U_1 , U_3 on the cone are also well-separated. As a result, the position of the plane passing through those three points is much less sensitive to errors in the determination of their positions, than in the earlier case.

How do we get the value of the half-parameter from two positions and the elapsed time between them? According to the Gauss-Kepler "area law," the area of the orbital sector between P_1 and P_3 , i.e., S_{13} , is equal to the product of (the elapsed time $t_3 - t_1$) \times (the square root of the half-parameter) \times (the constant π). The elapsed time is already known; if in addition we knew the area of the sector S_{13} , we could easily derive the value of the orbital parameter.

Another self-reflexive relationship! The exact value of S_{13} depends on the shape of the orbital arc between P_1 and P_3 ; but to know that arc, we must know the orbit. To construct the orbit, on the other hand, we need to know the orbital parameter, which in turn is a function of S_{13} .

Again, we can solve the problem using Gauss's method of successive approximations. The triangular area T_{13} , which we can compute directly from the positions P_1 and P_3 , already provides a first rough approximation to S_{13} . Better, we use $G \times T_{13}$, where G is Gauss's correction factor, calculated above. From such an estimated value for S_{13} , calculate the corresponding value of the orbital parameter. Next, apply our conical representation to constructing an orbit, using an approximation of the half-parameter, namely, the value corresponding to that estimated value of S_{13} .

Finally, with the help of Kepler's method of the "eccentric anomaly," or other suitable means, calculate the exact area of the sector S_{13} for that orbit. If this value coincides with the value we started with, our job is done. Otherwise, we must modify our initial estimate, until coincidence occurs. Gauss, who abhorred "dead mechanical calculation," developed a number of ingenious shortcuts, which drastically reduce the number of successive approximations, and the mass of computations required.

At the end of the process, we not only have the value of the orbital parameter, but also the orbit itself.

FIGURE 16.1. The elliptical orbit is easily determined from P_1, P_2, P_3 , by drawing the plane through the corresponding points U_1, U_2, U_3 (whose heights are the distances r_1, r_2, r_3 now known). However, Gauss rejected that direct method as being too prone to error when P_1, P_2, P_3 are close together.

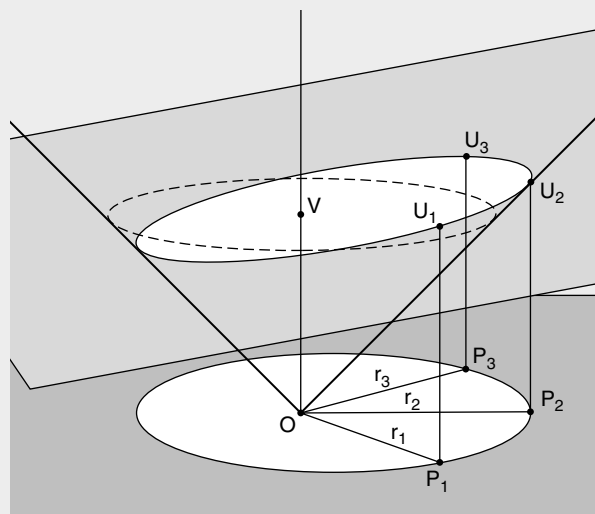

How To Perfect the Orbit

This completes, in broad essentials, Gauss's construction of a first approximation to the orbit of Ceres, using only three observations. Gauss did not base his forecast for Ceres on that first approximation, however. Remember, everything was based on our approximation to the Ceres position P_2 ; our construction of P_1 and P_3 , and the orbit itself, is only as good as P_2 .

Gauss devised an array of methods for successively improving the initially constructed orbit, up to an astonishing precision of mere minutes or even seconds of arc in his forecasts. Again, the key is the coherence and self-reflexivity of the relationships underlying the entire method.

The gist of Gauss's approach, as reported in the "Summary Overview," is as follows. How can we detect a discrepancy between the real orbit and the orbit we have constructed? By the very nature of our construction, *the first and third observations will agree precisely with the calculated orbit*: P_1 and P_3 lie on the calculated orbit as well as the lines of sight from E_1 and E_3 , and the elapsed time between them on our calculated orbit will coincide with the actual elapsed time between the first and third observations.

The situation is different for the intermediate position P_2 . If we calculate the position P_2 based on the proposed orbit—i.e., the position forecast at time t_2 —we will generally find that it disagrees by a more or less significant amount, from the " P_2 " we originally constructed. This "dissonance" tells us that the orbit is not yet correct. In

that case, we should gradually modify our estimate for P_2 , until the two positions coincide. Since P_2 must lie on the line-of-sight L_2 , the Earth-Ceres distance is the only variable involved.

Again, trial-and-error is feasible in principle, but Gauss elaborated an array of ingenious methods for successive approximation. Once he had arrived at an orbit which matched the three selected observations in a satisfactory manner, Gauss compared the orbit with the other observations of Piazzi, taking into account the vari-

ous possible sources of error. Finally, Gauss could deliver his forecast of Ceres' motion with solid confidence that the new planet would indeed be found in the orbit he specified.

Here our journey comes to an end—or nearly. For those readers who have taken the trouble to work through Gauss's solution with us, congratulations! Next chapter, we conclude with a *stretto*, on the issue of “non-linearity in the small.”

—JT

CHAPTER 17

In Lieu of a *Stretto*

In this closing discussion, we want to take on a famous bogeyman, called “college differential calculus.” Much more can and should be said on this, but the following should be useful for starters, and fun, too.

Readers may have noticed that Gauss made no use at all of “the calculus,” nor of anything else normally regarded as “advanced mathematics,” in the formal sense. Everything we did, we could express in terms of Classical synthetic geometry, the favorite language of Plato's Academy. Yet Gauss's solution for Ceres embodied something startlingly new, something far more advanced *in substance*, than any of his predecessors had developed. Laplace, famed for his vast analytical apparatus and technical virtuosity, was caught with his pants down.

Gauss's method is completely elementary, and yet highly “advanced,” at the same time. How is that possible?

Far from being a geometry of fixed axioms, such as Euclid's, Platonic synthetic geometry is a medium of metaphor—a medium akin to, and inseparable from the well-tempered system of musical composition. So, Gauss uses Classical synthetic geometry to elaborate a concept of physical geometry, which is axiomatically “anti-Euclidean.” A contradiction? Not if we read geometry in the same way we ought to listen to music: the axioms and theorems do not lie in the notes, but in the thinking process “*behind the notes*.”

Through a gross failure of our culture and educational system, it has become commonplace practice to impose upon the domain of synthetic geometry, the false, groundless assumption of *simple continuity*. It were hard to imagine any proposition, that is so massively refuted by the scientific evidence! And yet, if we probe into the minds of most people—including, if we are honest, among ourselves—we shall nearly always discover an area of fanatically irrational belief in simple continuity

and, what is essentially the same thing, linearity in the small. Here we confront a characteristic manifestation of oligarchical ideology.

Take, for example, the commonplace notion of circle, generated by “perfectly continuous” motion. Our imagination tells us that a small portion of the circle's circumference, if we were to magnify it greatly, would look more flat, or have less curvature, than any larger portion of the circumference. In other words: the smaller the arc, the smaller the net *change of direction* over that portion of the circumference.

Similarly, the standpoint of “college differential calculus” regarding any arbitrary, irregularly shaped curve, is to expect that the irregularity will decrease, and the curve will become simpler and increasingly “smooth,” as we proceed to examine smaller and smaller portions of it. This is indeed the case for the imaginary world of college calculus and analytical geometry, where curves are described by algebraic equations and the like. But what about the real world? *Is it true, that the adducible, net change in direction of a physical process over any given interval of space-time, becomes smaller and smaller, as we go from macroscopic scale lengths, down to ever smaller intervals of action?*

Well, in fact, *exactly* the opposite is true! As we pursue the investigation of any physical process into smaller and smaller scale-lengths, we invariably encounter an increasing density and frequency of abrupt changes in the direction and character of the motion associated with the process. Rather than becoming simpler in the small, the process appears ever more complicated, and its discontinuous character becomes ever more pronounced. Our Universe seems to be a very hairy creature indeed: a “discontinuum,” in which—so it appears—the part is more complex than the whole.

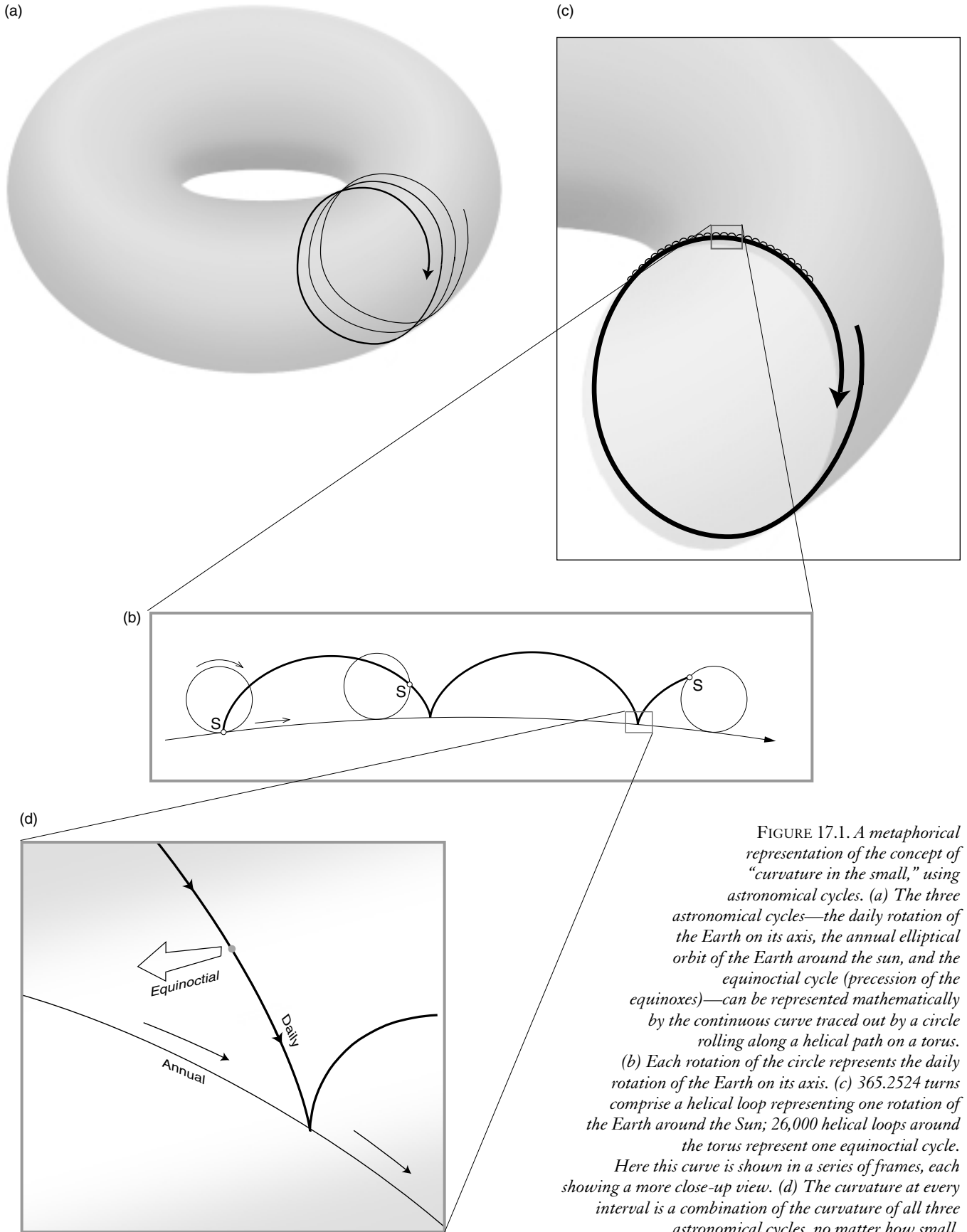

FIGURE 17.1. A metaphorical representation of the concept of “curvature in the small,” using astronomical cycles. (a) The three astronomical cycles—the daily rotation of the Earth on its axis, the annual elliptical orbit of the Earth around the sun, and the equinoctial cycle (precession of the equinoxes)—can be represented mathematically by the continuous curve traced out by a circle rolling along a helical path on a torus. (b) Each rotation of the circle represents the daily rotation of the Earth on its axis. (c) 365.2524 turns comprise a helical loop representing one rotation of the Earth around the Sun; 26,000 helical loops around the torus represent one equinoctial cycle. Here this curve is shown in a series of frames, each showing a more close-up view. (d) The curvature at every interval is a combination of the curvature of all three astronomical cycles, no matter how small.

‘Turbulence in the Small’

The existence of this discontinuum, this “turbulence in the small” of any real physical process, confronts us with several notable paradoxes and problems.

Firstly, what is the *meaning* of that “turbulence”? Why does our Universe behave that way? How does that characteristic—reflecting an increasing density of singularities in the “infinitesimally small”—cohere with the nature of human Reason? Why is a “discontinuum” of that sort, a *necessary* feature of the relationship of the human mind, as microcosm, to the Universe as a whole?

Another paradox arises, which may shed some light on the first one: When we carry our experimental study of a process down to the *microscopic level*, we find it more and more difficult to identify those features, which correspond to the *macroscopic* ordering that was the original object of our investigation.

The analogy of astronomic cycles, which we have learned something about through the course of our investigation, might help us to think about the problem in a more rigorous way. Instead of “macroscopic ordering,” let us say: a (relatively) long cycle. By the nature of the Universe, no single cycle exists in and of itself. All cycles interact, at least potentially; and the existence of any given cycle, is functionally dependent on a plenitude of shorter cycles, as well as longer cycles. Now we are asking the question: how does a given long cycle *manifest* itself on the level of much shorter cycles? At first glance, the action associated with the long cycle becomes more and more indistinct, and finally “infinitesimal,” as we descend to the length-scales characteristic of shorter and shorter cycles.

(More precisely—to anticipate a key point—we reach critical scale-lengths, below which it becomes *impossible* to follow the trace of the “long cycle” within the “short cycles,” unless we change our own axiomatic assumptions.)

We encounter this sort of thing all the time in astronomy. On the time-scale of the Earth’s daily rotation, the yearly motion of the sun appears as a very small deviation from a circular pathway. To the ancient observer, the effect of that deviation becomes evident only after many day-cycles. Similarly, recall the provocative illustration commissioned by Lyndon LaRouche, for the seemingly “infinitesimal” action of the approximately 25,700-year-long equinoctial cycle (precession of the equinoxes) within a one-second interval. (**Figure 17.1**)

The simplest sort of geometrical representation of such infinitesimal long-cycle action, tends to understate the problem: Suppose we did not know the existence or identity of a given long cycle. How could we uncover it

by means of measurements made only on a much smaller scale? Won’t the infinitesimally faint “signal” of the longer cycle, be hopelessly lost amidst the turbulent “noise” of the shorter cycles? Already in the case of Piazzi’s observations, the true motion of Ceres was completely distorted by the effect of the Earth’s motion. What would we do, if the cycle we were looking for were mixed together with not one, but a huge array of other cycles?

Here an unbridgeable chasm separates the method of Gauss, from that of Laplace and his latter-day followers. Just as Laplace ridiculed Gauss’s attempt to calculate the orbit of Ceres from Piazzi’s observations, calling it a waste of time, so Laplace’s successors, John Von Neumann, Norbert Wiener, and John Shannon, denied the *efficient* existence of long cycles, and sought to degrade them into mere “statistical correlations.”

The point is, we cannot solve the problem, as long as we avoid the issue of axiomatic change, and tacitly assume a simple commensurability between cycles which is tantamount to “linearity in the small.”

The Issue of Method

Let’s glance at some examples, where this issue of method arises in unavoidable fashion.

1. The paradoxes of any mechanistic theory of sound. “Standard theory,” going back to Descartes, Euler, Cauchy, *et al.*, treats air as a homogenous, “elastic medium,” within which sound propagates as longitudinal waves of alternate compression and decompression of the medium. Descartes’ “homogeneous elastic medium” is a fairy tale, of course. We know that the behavior of air depends on the existence of certain electromagnetic micro-singularities, called molecules. We can also be certain, that whatever sound *is* exactly, its propagation depends in some way on the functional activity of those molecules. At this point Boltzmann introduced the baseless assumption, only superficially different from that of Descartes and Euler, that the molecules are inert “simple bodies”—interacting only by elastic collisions in the manner of idealized tennis balls.

Experimental investigations leave little doubt, that the molecules in air are constantly in a state of a very rapid, turbulent motion at hypersonic speeds, and that events of rapid change of direction of motion take place among them, which one might broadly qualify with the term “collisions.” A single molecule will typically participate in hundreds of millions or more such events each second. On the other hand, those “colli-

sions” are anything but simple; they are vastly complicated electromagnetic processes, whose nature Boltzmann conveniently chose to ignore.

Push the resulting, simplistic picture to the limits of absurdity. Imagine observing a microscopic volume of the air, one inhabited by only a few molecules, on a time scale of billionths of a second. Where is the sound

wave? According to statistical method, the energy of the sound wave passing through any tiny portion of air is thousands, perhaps millions of times smaller than that of the turbulent “thermal” motion in a corresponding, undisturbed portion of air. What, then, is the sound wave for an individual air molecule, travelling at hypersonic speed, in the short time interval between

(a)

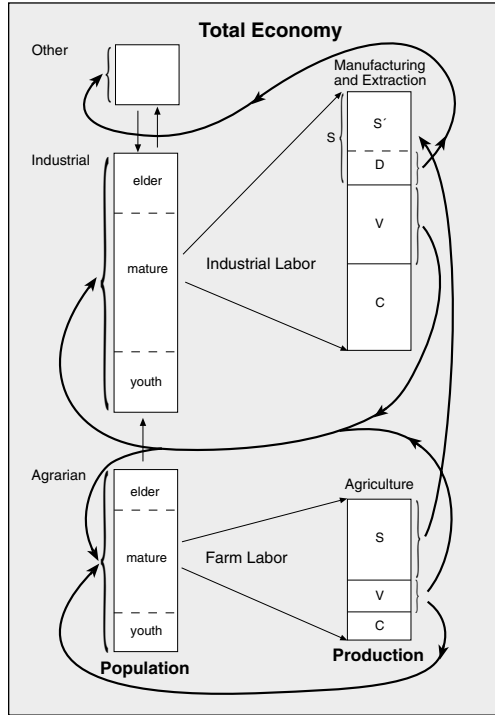

(b)

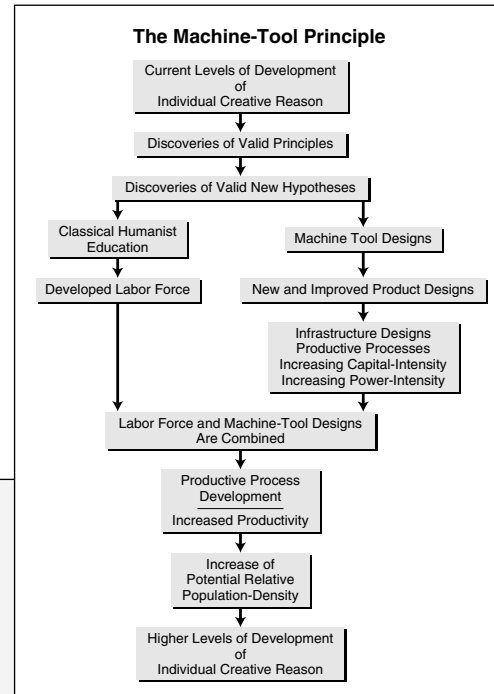

(a) Cycles of production and consumption change the internal composition of the labor force and capital. (b) Scientific discovery, technological innovation, and their assimilation into the productive economy. (c) Long-term cycle of demographic development.

(c)

FIGURE 17.2. Schematic representations used by Lyndon LaRouche to describe several crucial economic cycles. Like the astronomical cycles shown previously, these are embedded in one another, contributing simultaneously to the “action” of the productive economy at any given instant.

Growth of European Population, Population-Density, and Life-Expectancy

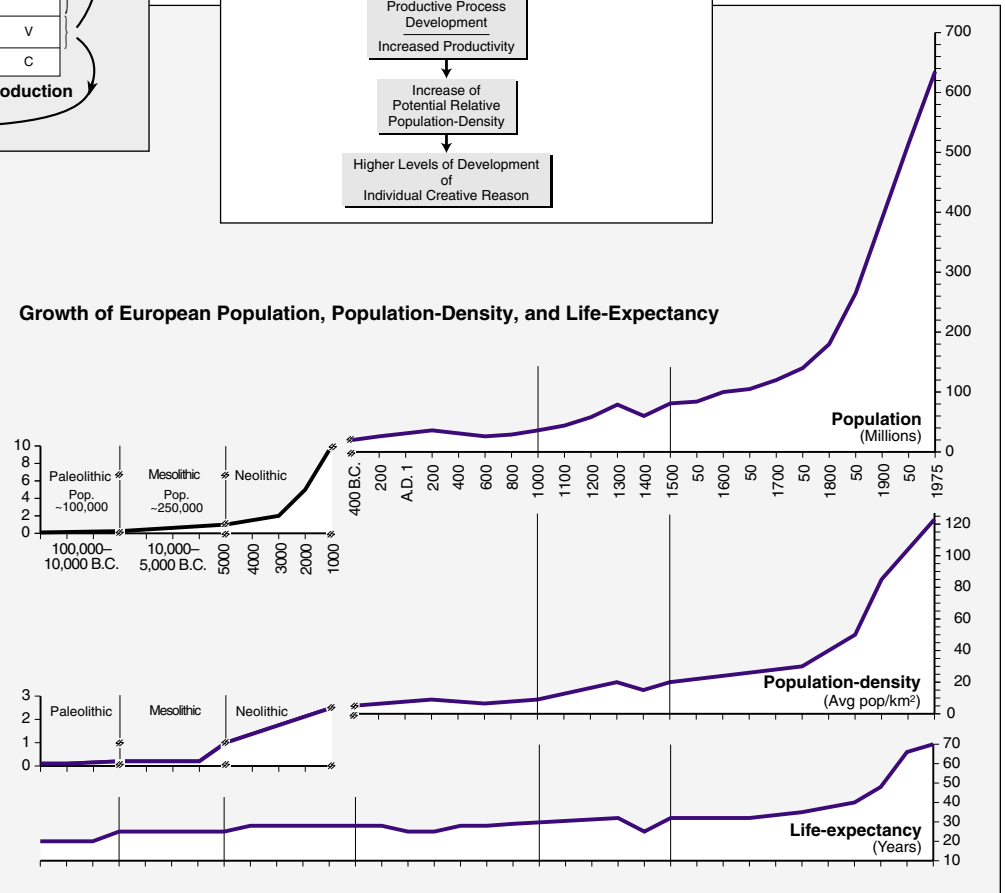

successive collisions? Does the sound wave exist at all, on that scale? According to Boltzmann, it does not: a sound wave is nothing but a statistical correlation—a mathematical ghost!

2. As implied, for example, by so-called photon effects, light is not a simple wave. Its propagation (even in a supposed “vacuum”) surely involves vast arrays of individual events on a subatomic scale. But standard quantum physics denies there is a strictly lawful relationship between the propagation of a light “wave” and the behavior of individual photons. Is “light” nothing but a statistical correlation?
3. The characteristic of living processes is self-similar conical-spiral action. But the *functional activity* of the electromagnetic singularities, upon which all known forms of life depend, is anything but simple and “smooth” in the way naive imagination would tend to misread the term, conical-spiral action. Going down to the microscopic level of intense, abrupt “pulses” of electromagnetic activity and millions of individual chemical events each second, how do we locate that which corresponds to the “long wave” characteristic, we call “living”?
4. A competent physical economist must keep track of a large array of cycles, subsumed within the overall social-reproductive cycle and the long cycle of anti-entropic growth of the *per-capita* potential population-density of the human species: demographic cycles, biological and geophysical cycles of agricultural and related production, production and consumption cycles of consumer and capital goods market-baskets, industrial and infrastructural investment/depreciation cycles interacting with the cycles of technological attrition, and so forth. (**Figure 17.2**) Where, within those cycles, is the causal agent of real economic growth?
5. Look at this from a slightly different standpoint: In the broad sweep of human history, we recognize a continuity of cultural development, reflected in orders-of-magnitude increases in the population potential of the human species. But that development is by definition a “discontinuum”: its very measure and focus is the individual human life, the quantum of the historical process. Nothing occurs “collectively,” as a “social phenomenon” excreted by some “*Zeitgeist*.” Nothing happens which is not the product of specific actions of individual human beings (including “non-actions”), actions bound up with the functions of the individual personality. Yet on the scale of historical “long cycles,” a human life is a short moment, with an abrupt beginning and an abrupt end. If we would take a microscope to history, so to speak, and examine the

hectic bustling and rushing around of an individual during his brief, pulse-like interval of existence, would we see the function which is responsible for the “long wave” of human development? Were it not as an “infinitesimal,” compared to the incessant hustling and bustling of existence? And yet, it is that “infinitesimal” which represents the most powerful force in the Universe!

A Well-Tempered ‘Discontinuum’

What lesson can we draw from these examples? The case of human society is the clincher: The efficient existence of the long cycle within the shorter cycles, is located uniquely in the *axiomatic characteristics of action in the small*.

Thus, the relationship between short and long cycles does not exist in the domain of naive sense-certainty; nor is it capable of literal representation in formal mathematics. To adduce axiomatic characteristics and shifts in such characteristics, is the exclusive province of human cognition! What characteristics necessarily apply to the short cycles, by virtue of their participation in the coming-into-being of a given long cycle? In this context, recognize the unique potential of the self-consciously creative individual, by deliberately changing the axioms of his or her action, to shift the entire “orbit” of history for hundreds or thousands of years to come! To command the forces of the Universe, we need not know all the details and instrumentalities of a given process; we have only to address its essential axiomatic features.

Gauss’s solution for Ceres is coherent with this point of view. His is not a simple construction, in the sense of classroom Euclidean geometry. To solve the problem, we had to focus on the significance of the fact, that there is no simple commensurability or linear-deductive relationship between

- (i) the angular intervals formed by Piazzi’s observations from the Earth;
- (ii) the corresponding three positions of Ceres in space;
- (iii) the orbital process generating the motion of Ceres, and the “elements” of the orbit, taken as a completed entity;
- (iv) the Keplerian harmonic ordering of the solar system as a whole, subsuming a multitude of astronomical cycles of incommensurable curvature.

We had to ask ourselves the question: What *harmonic relationship* must underlie the array of intervals among the observed positions of Ceres, by virtue of the fact, that those apparent positions were generated by the combined action of the Earth and Ceres (and, implicitly, the rest of the solar system)? As Kepler emphasized, it is in the harmonic, geometrical relationships—and not in nominal scalar magnitudes *per se*, whether small or large—that

the axiomatic features of physical action are reflected into visual space.

The crucial feature, emerging ever more forcefully in the course of our investigation, was expressed by the coherence and at the same time the incommensurable discrepancy, between the triangular areas of the discrete observations on the one hand, and the orbital sectors on the other. This is the same motif addressed by Gauss's

earliest work on the arithmetic-geometric mean. What shall we call it? A "well-tempered discontinuum"!

As an exercise, we invite the reader to apply the essence of Gauss's method concerning the relationship of the various levels of becoming, to the completed conception of a Classical musical composition. For, you see, there is yet another mountaintop!

—JT

APPENDIX

Harmonic Relationships In an Ellipse

(a)

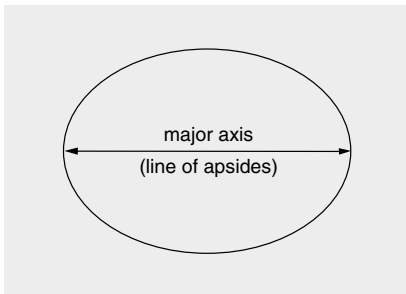

(b)

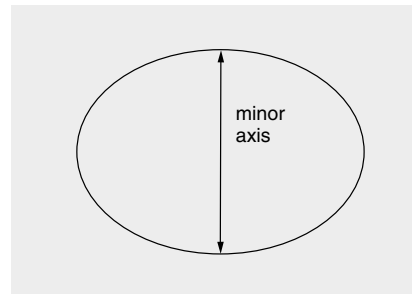

(c)

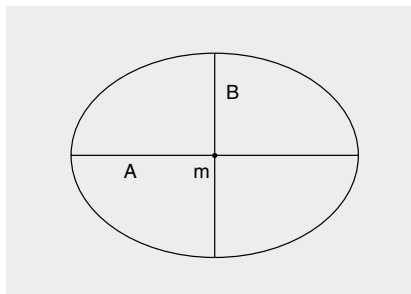

A and B are the semi-major and semi-minor axes, and m is the midpoint, or center, of the ellipse

(d)

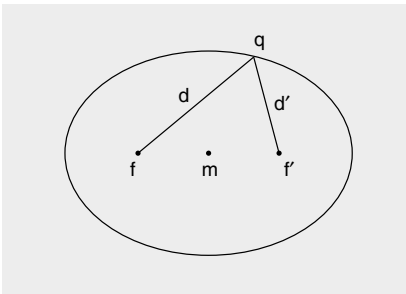

The characteristic property of the ellipse: The sum of the distance from an arbitrary point q on the perimeter, to the two foci f, f' , is a constant:

$$d + d' = \text{constant.}$$

(e)

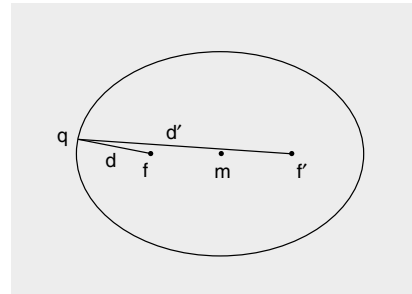

To determine the value of the sum of distances, consider the case, where q approaches the point on the major axis opposite f . At that point, we can see that the total length $d + d'$ will be equal to the major axis of the ellipse:

$$d + d' = 2A.$$

(f)

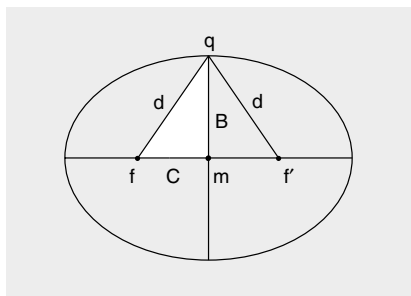

Applying the Pythagorean Theorem to the right triangle mfq , we find, that $d^2 = B^2 + C^2$. Since length d from focus f to q is equal to the semi-major axis A , and the total length $d + d = 2A$, we have the relationship between the semi-major axis A , the semi-minor axis B , and the

distance C from the focus to the midpoint m :

$$A^2 = B^2 + C^2,$$

or

$$C^2 = A^2 - B^2$$

$$C = \sqrt{A^2 - B^2}.$$

(g)

Another set of characteristic singularities: a point moving on the ellipse, reaches its maximum distance (α) from the focus f , at point a (called the “aphelion”), and its minimum distance (β) at the point p (called the “perihelion”).

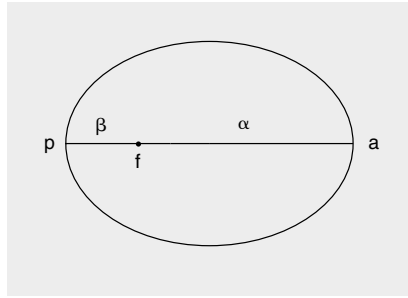

(h)

The ellipse spans the intervals between two characteristic sets of circles: the circles of radii A, B around the mid-point of the ellipse, and the circles of radii α, β around the focus f . What is the relationship between A, B and α, β ?

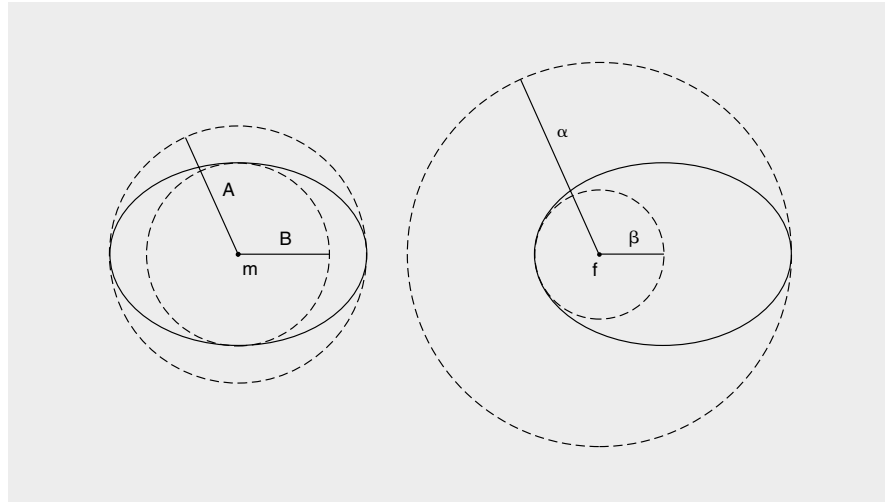

(i)

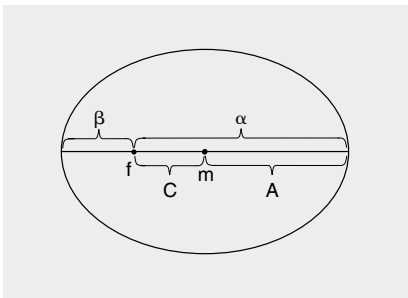

$\alpha + \beta =$ major axis of ellipse

$$= 2A$$

$$A = \frac{\alpha + \beta}{2} .$$

Also, from the diagram,

$$C = \alpha - A$$

$$= \alpha - \frac{\alpha + \beta}{2}$$

$$= \frac{\alpha - \beta}{2} .$$

(j)

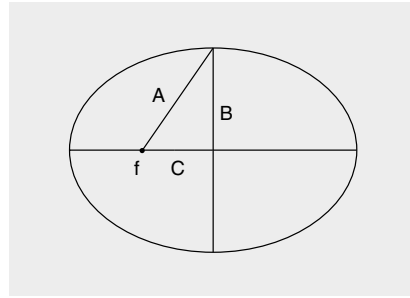

From figure (f), we have the relationship

$$A^2 = B^2 + C^2 .$$

From this, it follows that

$$\begin{aligned} B^2 &= A^2 - C^2 \\ &= \left(\frac{\alpha + \beta}{2}\right)^2 - \left(\frac{\alpha - \beta}{2}\right)^2 \\ &= \left(\frac{\alpha^2 + \beta^2 + 2\alpha\beta}{4}\right) \\ &\quad - \left(\frac{\alpha^2 + \beta^2 - 2\alpha\beta}{4}\right) \\ &= \alpha\beta ! \\ B &= \sqrt{\alpha\beta} . \end{aligned}$$

$A = (\alpha + \beta) / 2$ and $B = \sqrt{\alpha\beta}$ are known as the *arithmetic* and *geometric means* of lengths α and β . The combination of the two, inherent in the geometry of the ellipse, plays a key role in Gauss’s founding of a theory of elliptic and hypergeometric functions, based on his concept of what is called the “arithmetic-geometric mean.”

The Orbital Parameter

(k)

Still another key singularity, already presented in the text, is the “orbital parameter,” which is the length of the perpendicular qq' to the major axis at the focus f . The value Gauss most frequently works with in his calculations, is the “half-parameter” qf , corresponding to the radius in the case of a circular orbit.

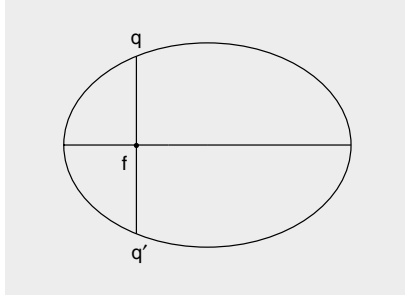

(l)

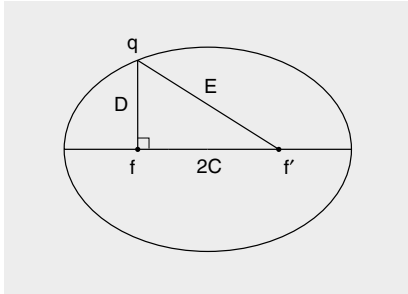

To calculate the relationship between the half-parameter (labelled “ D ”) and the semi-axes A, B , one way to proceed is as follows: From the characteristic of generation of the ellipse,

$$E + D = 2A \text{ (major axis).} \quad (\text{A1})$$

Apply the Pythagorean Theorem to the right triangle fqq' :

$$\begin{aligned} E^2 - D^2 &= (2C)^2, \text{ or} \\ E^2 - D^2 &= 4C^2. \end{aligned} \quad (\text{A2})$$

On the other hand, by factoring, we have

$$\begin{aligned} E^2 - D^2 &= (E - D)(E + D) \\ &= (E - D) \cdot 2A \end{aligned} \quad (\text{A3})$$

[by Equation (A1)].

From Equations (A2) and (A3), we have

$$E - D = \frac{4C^2}{2A} = \frac{2C^2}{A}. \quad (\text{A4})$$

Subtracting Equation (A4) from Equation (A1), we find

$$2D = 2A - \frac{2C^2}{A}$$

$$D = \frac{A^2 - C^2}{A} = \frac{B^2}{A}.$$

This result becomes much more intelligible in terms of conical projections.

Expressed in terms of the aphelion and perihelion distances, we have

$$\begin{aligned} D &= \frac{B^2}{A} = \frac{\alpha\beta}{(\alpha + \beta)/2} \\ &= \frac{2\alpha\beta}{\alpha + \beta} = \frac{2}{(1/\alpha) + (1/\beta)}. \end{aligned}$$

The latter value is known as the *harmonic mean* of α and β .

In summary, the semi-major axis, semi-minor axis, and half-parameter of an orbit, correspond to the *arithmetic, geometric, and harmonic means* of the aphelion and perihelion distances. These three means played a central role in the geometry, music, architecture, art, and natural science of Classical Greece

(m)

The intimate relationship to the musical system can be seen, for example, if we interpret *lengths* as signifying frequencies (or pitches), and consider the case, where $\alpha = 2\beta$ (length α corresponds to a pitch one octave higher than β). If β is “middle C,” then the pitches corresponding to the various elliptical singularities will be as labelled in the figure.

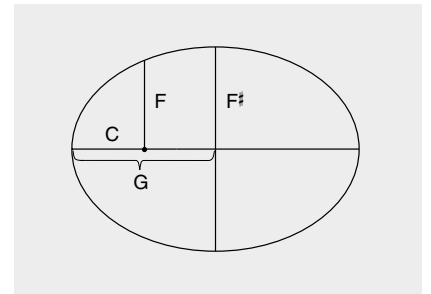

The interval $F-F^\sharp$ is the key singularity of the musical system.

The Ellipse as a Conical Projection

The underlying harmonic relationships in an ellipse become more intelligible, when we conceive the ellipse as a kind of “shadow” or projection from a higher, conical geometry. The implications of this are discussed in Chapter 12; here, we explore only the “bare bones” of the relevant geometrical construction.

(n)

Given a horizontal plane and a point f on that plane, erect a vertical axis at f and construct a vertical-axis cone having its apex at f and its apex angle equal to 90° .

Note a crucial feature of the relationship between cone and horizontal plane: for any point q in the plane, the distance d from f to q , is equal to the “height” h of the point Q lying perpendicularly above q on the cone.

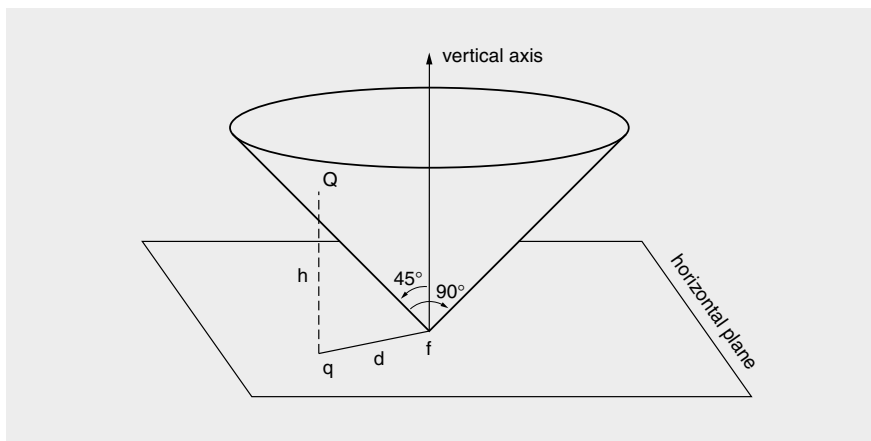

(o)

Now, cut the cone with a plane, generating a conic section. For the present discussion, consider the case, where the cutting plane makes an angle of more than 45° with the vertical axis. In this case, the conic section will be an ellipse. Now, project that curve vertically downward to the horizontal plane. The result, as we shall verify in a moment, is an ellipse having f as a focus.

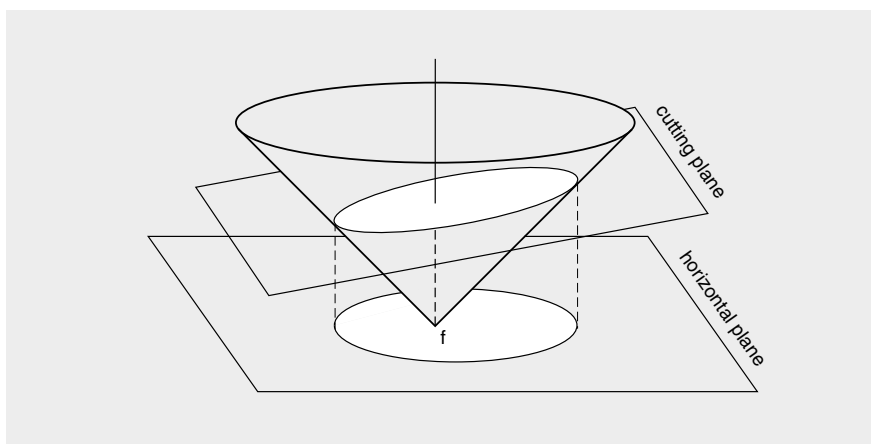

(p)

To explore the relationship so generated, examine the above figure as projected onto a plane passing through the vertical axis and the major axes of the two ellipses. (That plane makes right angles with both the cutting plane and the horizontal plane.)

With a bit of thought, we can see that the segment fV is equal to the segment D [in figure (l)], which defines the half-parameter of the projected ellipse. (Indeed, the endpoint q of the segment D on the ellipse, coincides with the position of f when the ellipse is viewed “edge-on” perpendicular to its major axis; the point Q , on the cone above q , coincides with V in the projection, and

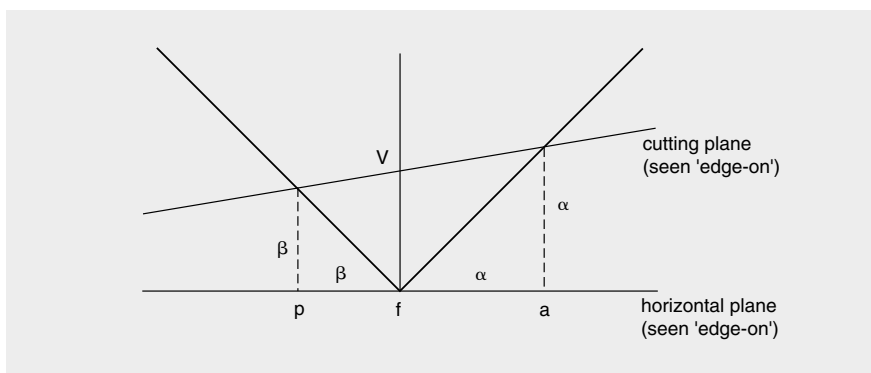

its height, which is equal to D , coincides with fV .) Those skillful in geometry can easily determine the length fV in terms of α and β from the diagram.

The result is $fV = 2\alpha\beta / (\alpha + \beta)$, confirming the expression for the half-parameter which we found by another method above in (l).

(q)

Double-conical projection. The ellipse formed by the original plane-cut of the cone, can also be realized as the intersection of that cone with a second cone, congruent to the first, but with the opposite orientation, and whose axis is a vertical line passing through the point f' lying symmetrically across the midpoint m of the projected ellipse from f .

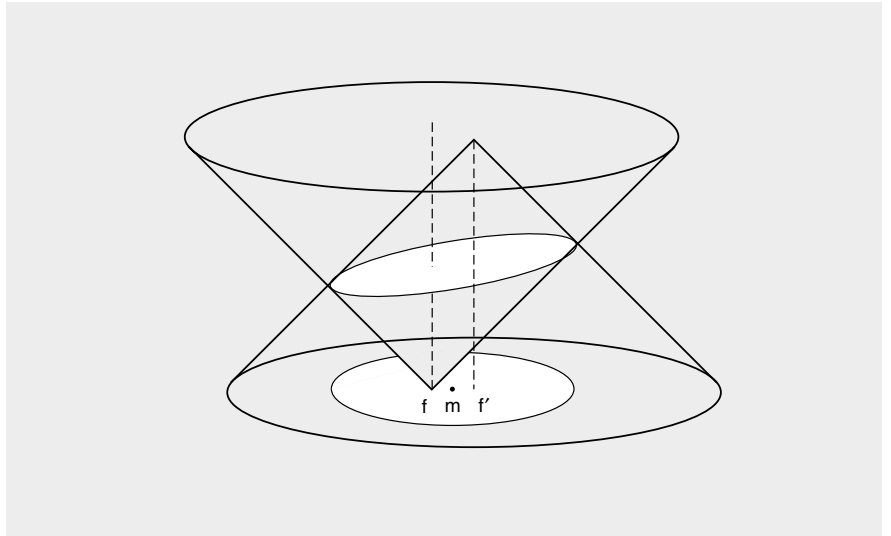

(r)

Looking at the double-conical construction in the “edge-on” view as before, we can now see why the points f, f' , corresponding to the apex-points of the cones, coincide with the foci of the ellipse. Let q represent an arbitrary point on the perimeter of the projected ellipse, let Q represent the corresponding point on the conical section. Then, by virtue of the symmetry of the construction and the relationship between “heights” and distances to the points f and f' , Qq and Qq' are equivalent, respectively, to the true distances from q to f and f' (i.e., the real distance in the plane of the projected ellipse, not those in the “edge-on” view). Since the distance between the two horizontal

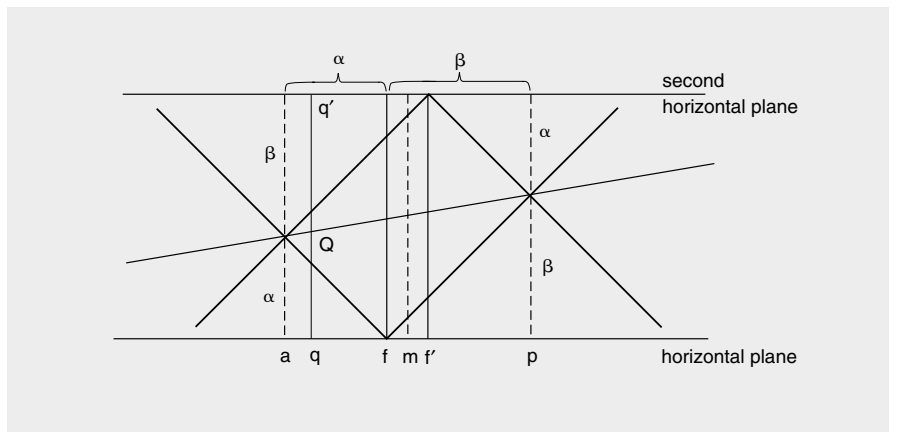

planes in the diagram is constant, $Qq + Qq'$ is constant, and therefore so is the sum of the distance qf and qf' .

—Jonathan Tennenbaum

FOR FURTHER READING

- Nicolaus of Cusa** “On the Quadrature of the Circle,” trans. by William F. Wertz, Jr., *Fidelio* (Spring 1994).*
- William Gilbert** *De Magnete (On the Magnet)*, trans. by P. Fleury Mottelay (New York: Dover Publications, 1958; reprint).*
- Johannes Kepler** *New Astronomy*, trans. by William Donahue (London: Cambridge University Press, 1992).
Epitome of Copernican Astronomy (Books 4 and 5) and *Harmonies of the World* (Book 5), trans. by Charles Glenn Wallis (Amherst: Prometheus Press, 1995; reprint).*
- The Harmony of the World*, trans. by E.J. Aiton, A.M. Duncan, and J.V. Field (Philadelphia: American Philosophical Society, 1997).*
- G.W. Leibniz** “On Copernicus and the Relativity of Motion,” “Preface to the *Dynamics*,” and “A Specimen of Dynamics,” in *G.W. Leibniz: Philosophical Essays*, trans. by Roger Ariew and Daniel Garber (Indianapolis: Hackett Publishing Company, 1985).*
- Carl F. Gauss** *Theory of the Motion of the Heavenly Bodies Moving about the Sun in Conic Sections*, trans. by Charles Henry Davis

(New York: Dover Publications, 1963; reprint).*

Bernhard Riemann “On the Hypotheses Which Lie at the Foundation of Geometry,” in *A Source Book in Mathematics*, ed. by David Eugene Smith (New York: Dover Publications, 1959; reprint).*

Lyndon H. LaRouche, Jr. The key methodological features of the works of Kepler, Leibniz, and Gauss, in opposition to the corruptions introduced by Sarpi, Galileo, Newton, and Euler, are a central theme in all the writings of Lyndon H. LaRouche, Jr. Among articles of immediate relevance to the matters presented here, are the following works which have appeared in recent issues of *Fidelio*: “The Fraud of Algebraic Causality” (Winter 1994); “Leibniz From Riemann’s Standpoint” (Fall 1996); “Behind the Notes” (Summer 1997); “Spaceless-Timeless Boundaries in Leibniz” (Fall 1997). See also LaRouche’s book-length “Cold Fusion: Challenge to U.S. Science Policy” (Schiller Institute Science Policy Memo, August 1992).*

* Starred items may be ordered from Ben Franklin Booksellers. See advertisement, page 111, for details.